

CYCLONES

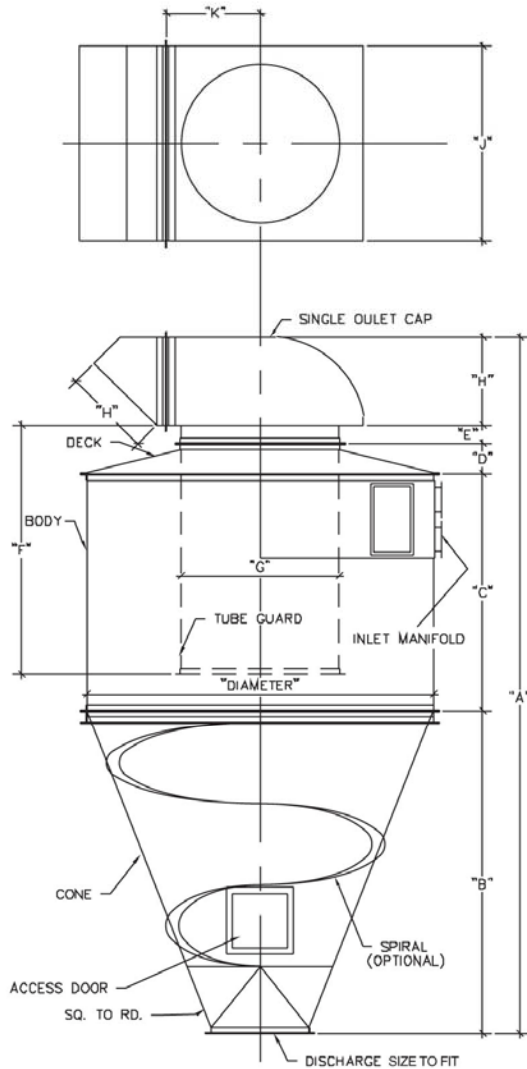

TUBE GUARD TYPE

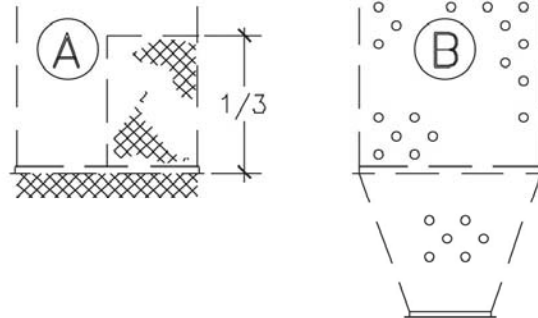

A

For corrugated and folding carton. 180° expanded metal 1/3 of the way up the tube guard with expanded metal bottom.

B

For light paper products. Perforated tube guard with perforated cone.

**Trim Collection Systems • Balers
Touch Screen & Motor Control Centers
Blowers & Fans • Cyclones**

240 Airport Road • Gallatin, TN 37066
Phone (615) 230-9500 • Fax (615) 230-9592
Email: sales@gfpuhl.com • www.gfpuhl.com



DIA.	SIZE	MAX. CFM CAPACITY	
		CORRUG.	PAPER
5'-0"	45	4500	4000
6'-0"	80	8000	7200
7'-0"	100	10000	9000
8'-0"	120	12000	10800
9'-6"	188	18800	16900
10'-0"	217	21700	19500
11'-0"	246	24600	22100
12'-0"	300	30000	27000
13'-0"	350	35000	31500
14'-0"	400	40000	36000
15'-0"	490	49000	44100
16'-0"	550	55000	49500
17'-0"	610	61000	54900
18'-0"	700	70000	63000
21'-0"	103	103,970	95,070

DIA.	A	B	C	D	E	F	G	H	J	K
5'-0"	9'-4"	5'-0"	4'-0"	0'-5"	0'-5"	3'-10"	2'-2"	1'-5"	2'-7"	1'-7"
6'-0"	12'-11"	6'-0"	4'-6"	0'-5"	0'-5"	4'-4"	2'-11"	1'-7"	3'-3"	1'-10 1/2"
7'-0"	14'-6"	7'-0"	4'-9"	0'-6"	0'-5"	4'-8"	3'-3"	1'-10"	3'-7"	2'-0 1/2"
8'-0"	16'-0"	8'-0"	5'-0"	0'-6"	0'-6"	5'-0"	3'-6"	2'-0"	3'-10"	2'-2"
9'-6"	19'-9"	9'-6"	6'-6"	0'-10"	0'-6"	6'-10"	4'-4"	2'-5"	4'-8"	2'-7"
10'-0"	20'-8"	10'-0"	6'-9"	0'-10"	0'-6"	7'-2"	6'-1"	2'-7"	6'-6"	3'-5 1/2"
11'-0"	22'-2"	11'-0"	7'-0"	1'-0"	0'-6"	7'-6"	6'-6"	2'-8"	6'-11"	3'-8"
12'-0"	24'-8"	12'-0"	8'-0"	1'-2"	0'-6"	8'-8"	7'-2"	3'-0"	7'-7"	4'-0"
13'-0"	26'-5"	13'-0"	8'-6"	1'-2"	0'-6"	9'-4"	7'-9"	3'-3"	8'-2"	4'-3 1/2"
14'-0"	28'-5"	14'-0"	9'-0"	1'-3"	0'-8"	9'-11"	8'-3"	3'-6"	8'-8"	4'-6 1/2"
15'-0"	30'-6"	15'-0"	9'-6"	1'-4"	0'-8"	10'-6"	9'-2"	4'-0"	9'-7"	5'-0"
16'-0"	31'-8"	16'-0"	9'-6"	1'-5"	0'-8"	10'-7"	9'-8"	4'-1"	10'-1"	5'-3"
17'-0"	33'-6"	17'-0"	10'-0"	1'-6"	0'-8"	11'-2"	10'-2"	4'-4"	10'-7"	5'-6"
18'-0"	34'-11"	18'-0"	10'-0"	1'-7"	0'-8"	11'-3"	10'-11"	4'-8"	11'-4"	5'-10 1/2"
21'-0"	38'-11"	21'-0"	10'-0"	1'-7"	0'-9"	11'-9"	13'-0"	5'-8"	13'-5"	13'-8"

