

- PUHL TRIM SEPARATOR -

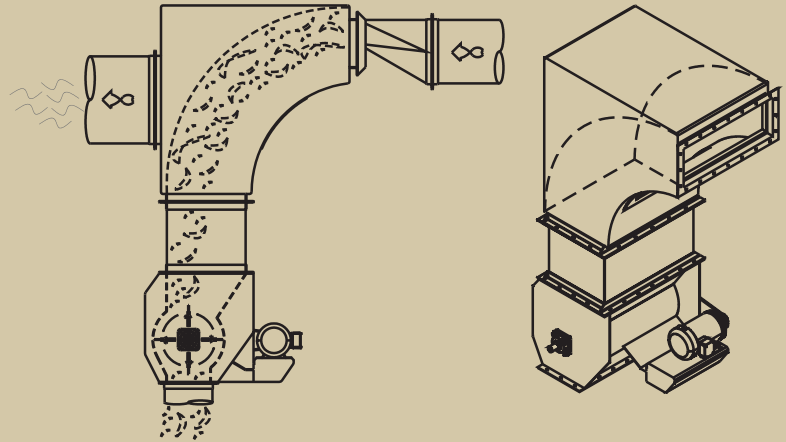

Note: Guard removed In drawing for viewing purposes.

Trim separators are compact and effectively reduce the space and roof height requirements as compared to a conventional cyclone system.

Puhl Trim Separator Features:

- **Curved screen improves separation efficiency with reduced plugging.**
- **Clear viewing window for visual inspection and tool-less easy access.**
- **Quick replace screen removable frame from side.**
- **Adjustable airfoil design to allow airflow and material speed adjustment.**
- **Optional heavy duty airlock.**
- **Replaceable airlock blade tips.**
- **Installations can be made in parallel (side by side configuration)**
- **Can be installed to saddle onto an existing trim waste duct system as a concentrator.**



G.F. Puhl Company Inc.

**240 Airport Road • Gallatin, TN 37066 • (615) 230-9500 • Fax (615) 230-9592
Email: sales@gfpuhl.com • www.gfpuhl.com**

- PUHL TRIM SEPARATOR -

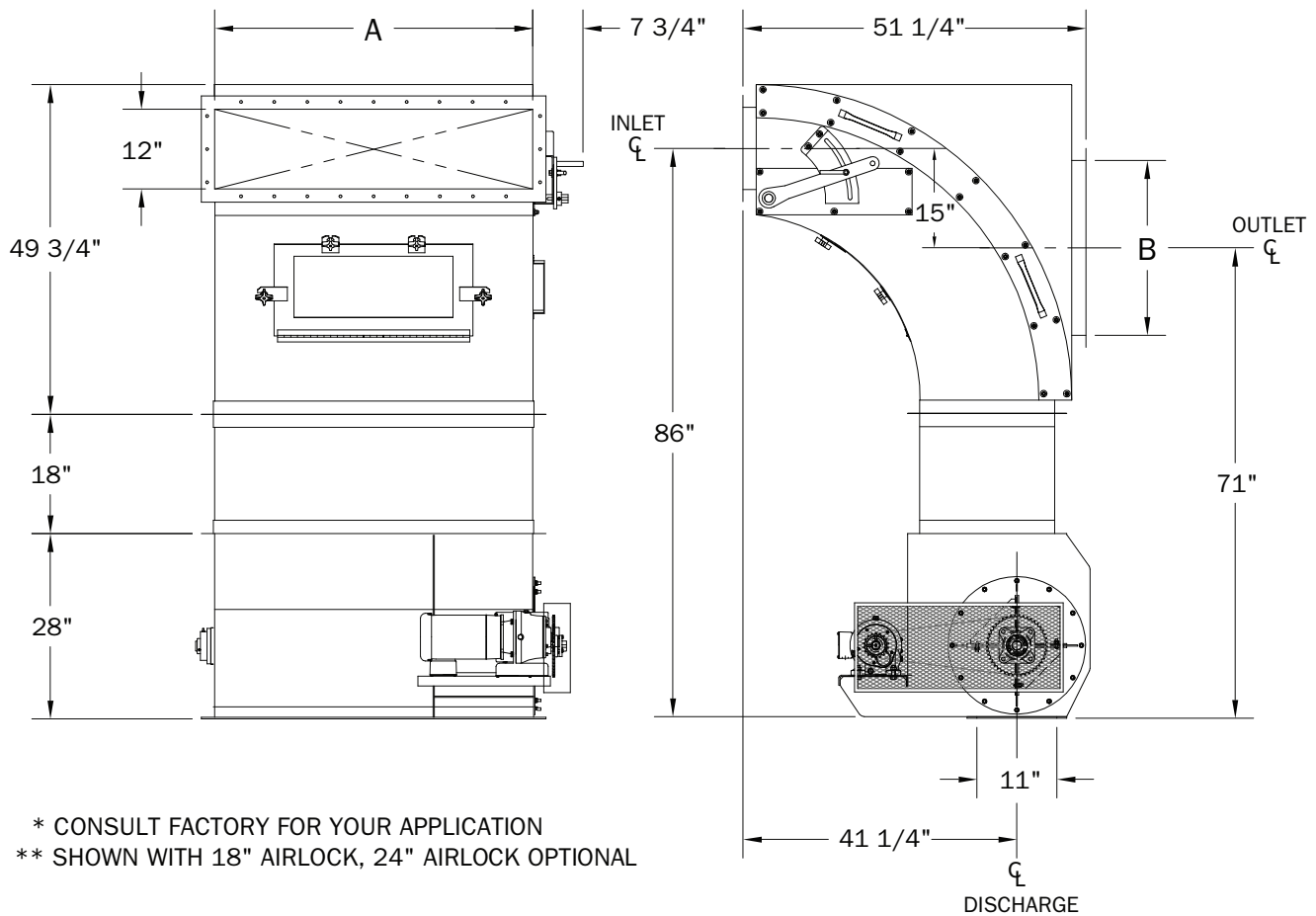

- DIMENSION TABLE -

FLOW (CFM)	PTS MODEL	A	B MAX.	WEIGHT (LB)	AIRLOCK MODEL	WEIGHT (LB)	MOTOR (HP)
4000	8150	24"	18"	355	9150	330	3/4
6000	8250	32"	22"	410	9250	475	1 1/2
7000	8300	36"	24"	440	9350	560	1 1/2
9000	8400	48"	26"	490	9400	650	1 1/2
12,500	8500	60"	30"	565	9500	750	3
14,500	8600	70"	34"	620	9600	830	3
18,700	8700	90"	34"	735	9700	990	5
26,000	9000	120"	44"	860	9800	1250	5



The G.F. Puhl Company, Inc.

240 Airport Road • Gallatin, TN 37066
 (615) 230-9500 • Fax (615) 230-9592